

Series DW

2 Port Solenoid Valve



● WIDER RANGE OF OPERATING PRESSURE

- 0 ~ 7 kgf/cm²(DW03)
- 0.3~7 kgf/cm²(DW10, 15)
- 0.3 ~ 10 kgf/cm²(DW20, 25)

● HIGH FLOW CAPACITY

● LOW VOLTAGE SOLENOID

● CAN BE MOUNTED ANY WHERE

Symbol

Direct Acting Type
(N. C.)

Air Pilot Type
(N. C.)

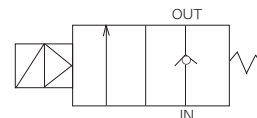
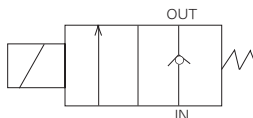

How to Order

DW 10 — 1 C — 01 VC

1 2 3 4 5 6 7

1 2 Port Solenoid Valve Applicable Fluid (Water, Air, Oil) ※Option: Steam

2 Body(Orifice Size)

03 : φ 2.5-Direct Type Solenoid
10 : φ 10 Pilot Type Solenoid
15 : φ 15
20 : φ 20
25 : φ 25

3 Voltage

1 : AC100V, 50/60Hz
2 : AC200V, 50/60Hz
5 : DC24V
9 : Others

4 Electric Connection

G : Grommet (only Rc(PT) 1/8)
C : Conduit

5 Port Size Rc(PT)

01 : 1/8
02 : 1/4
03 : 3/8
04 : 1/2
06 : 3/4
10 : 1

6 Blank : Standard

S : SUS Type

7 VC : Vacuum Type(-100kpa) (only AC Voltage)

Standard Specifications

Applicable	Air, Water, Oil		
Proof Pressure	1.5MPa(213.35psi)		
Fluid Temperature	0~70° C(32° F~158° F)		
Ambient and fluid temperature	Max. 60° C(140° F)		
Electrical Entry	Grommet, Conduit		
Actuation Type	Direct or Pilot Solenoid		
Valve Type	Normal Close		
Seat Type	Poppet		
Rated Voltage	AC (50/60Hz)	100V, 200V	
	DC	24V	
Allowance Voltage Range	Rated Voltage ± 10%		
Coil Insulation	Class B or Equivalent 110° C(230° F)		
Power Consumption	AC	Inrush	17VA (60Hz)
		Holding	15VA (60Hz)
	DC		11W

DW

DV100

DV1000 -
3000 - 4000

DS300

DS3000

DS5000

DS2000

DX2R

DP300 -
3000 - 5000

DS6000

DX2

DM

DH

DT220

DC

Applicable Specifications

Coil Apparent Power	AC110, 220V(50/60Hz)
	DC 6, 12V
Body Material	Stainless steel(SCS13)
Coil Insulation	H Class(180°C)(356°F)
	AC100, 110, 200, 220V Only

Model

Type	Port (Size)	Pressure		Orifice Size (φ mm)	Effective Orifice (mm ²)	Weight (kgf)
DW03→G-01	1/8(6A)	0~0.7MPa (0~99.5psi)		.5	6	0.3
DW03→G-02	1/4(8A)			2.5	6	0.3
DW10→C-02	1/4(8A)	AC: 0~1MPa (0~140.2psi)	DC: 0.03~0.7MPa (4.27~99.5psi)	10	34	0.5
DW10→C-03	3/8(10A)			10	43	0.5
DW15→C-04	1/2(15A)			15	160	0.7
DW20→C-06	3/4(20A)	0.03~1MPa (4.27~140.2psi)		20	170	0.9
DW25→C-10	1(25A)			25	225	1.2

Dimensions

mm(inch)

DW □ 03 - □ G - ⁰¹/₀₂

Symbol

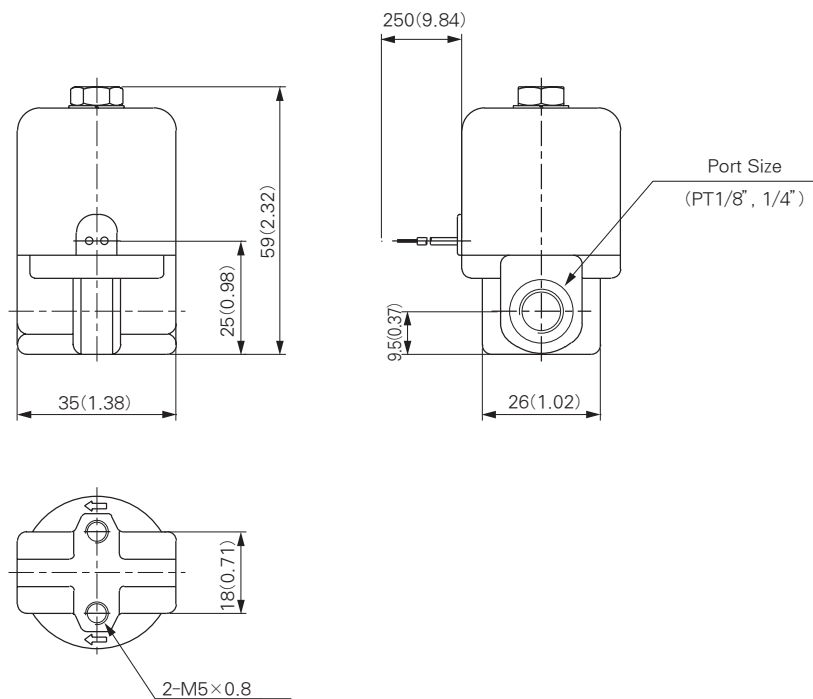
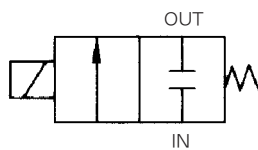

Dimensions

mm(inch)

DW 10 - □C- 02
03

Symbol

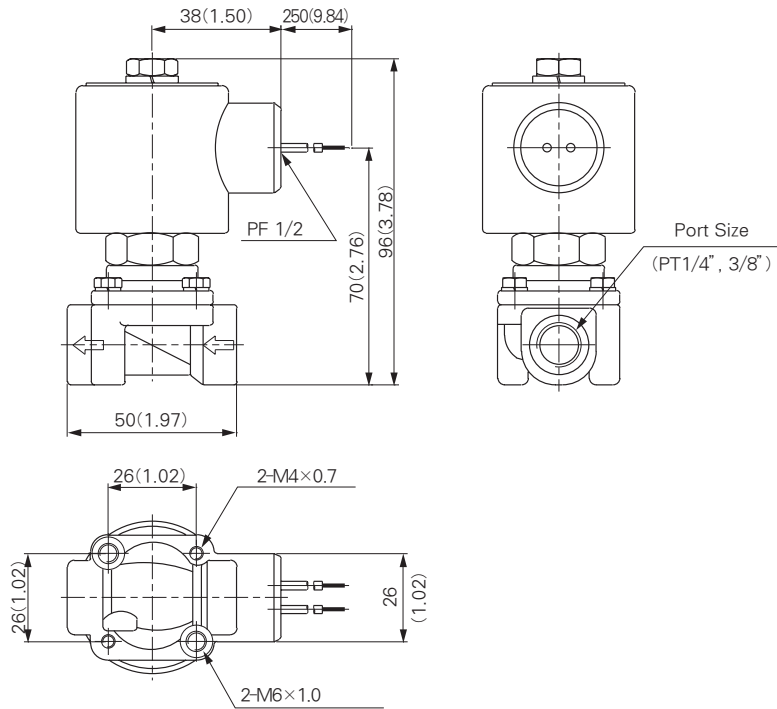
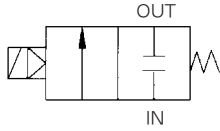

Dimensions

mm(inch)

DW15 - □C - 04

Symbol

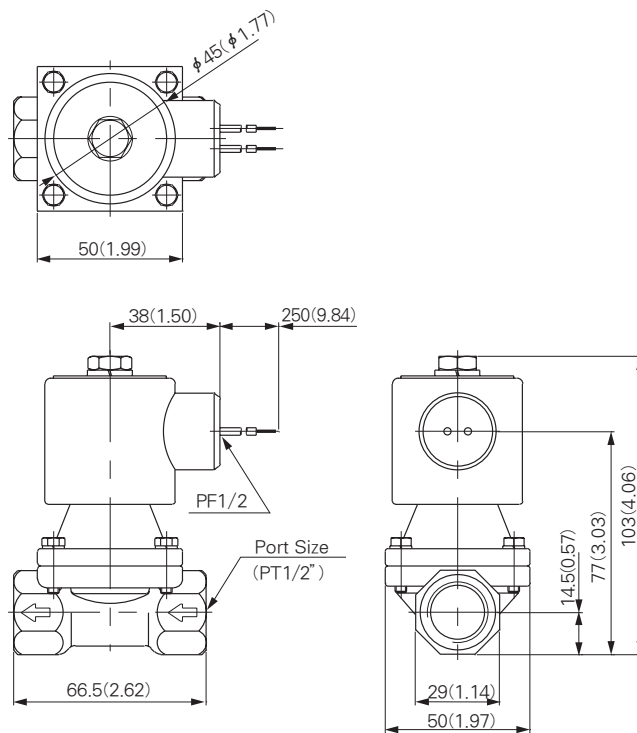
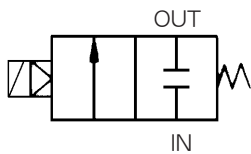

DW

DV100

DV1000 -
3000 - 4000

DS300

DS3000

DS5000

DS2000

DX2R

DP300 -
3000 - 5000

DS6000

DX2

DM

DH

DT220

DC

Dimensions

mm(inch)

DW 20 - □C - 06
 DW 25 - □C - 10

Symbol

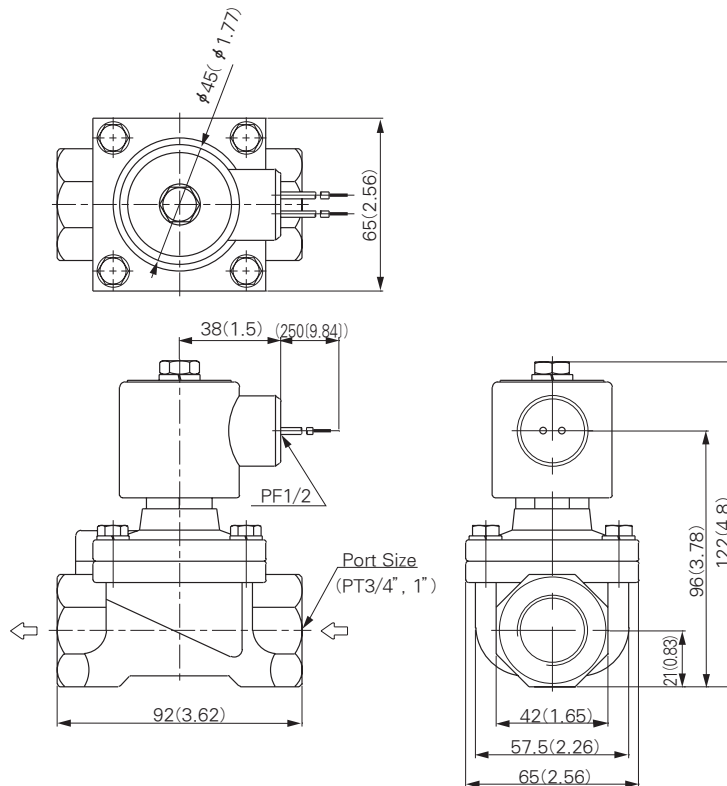
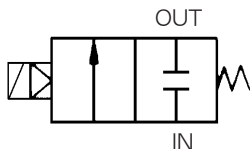

Precautions

Piping

- ❶ Piping should be thoroughly flushed to remove sludge, cutting oil, and dust.
- ❷ During piping and coupling connection, care should be taken to prevent contamination by cut thread chips or sealing materials. (When applying sealing tape to threads, one screw thread should extend beyond the tape.)
- ❸ Pay attention to the piping direction (IN, OUT). IN or other marks are indicated on the inlet side.
- ❹ The coil should not be subjected to an extended force. When tightening, apply a wrench to the outside of the pipe mounting area only.
- ❺ The piping system should not be grounded. Grounding would cause electrolytic corrosion.
- ❻ To prevent collection of fluid within the piping circuit, install a relief valve within the circuit.

Wiring

- ❶ The minimum diameter for wire connection is 0.5mm^2 .
- ❷ An electric circuit which prevents chattering at the point of contact should be employed.
- ❸ When the electric is apt to be damaged by surge voltage, place a surge suppressor in parallel with the solenoid voltage suppressor (option).
- ❹ The allowable voltage range is $-10\% \sim +10\%$ of the rated voltage. However, if great response is desired for DC power, the voltage range should be within $\pm 5\%$ of the rated voltage. Voltage drop is measured at a part of the lead wire connected to the coil.
- ❺ The voltage found on both ends of the coil, when it deenergizes, is: AC: 20% or less of the rated voltage DC: 2% or less of the rated voltage
 The DC value is for a temperature of $20 \pm 5^\circ\text{C}$.
 At lower temperatures, the DC value will be lower.

Mounting

- ① The solenoid valve may be mounted in any orientation.
When mounted upside down, however, foreign material in the fluid is liable to adhere to the iron core. Avoid such a mounting method. Mount the valve with its coil facing up.
- ② Do not keep coil assemblies warm with insulating material, etc. It will cause the coil to burn out. Antifreezing tape, heater, etc., should be applied to piping and body areas only.
- ③ Do not place the valve in areas of severe vibration. If it is unavoidable, shorten the arm to a minimum to avoid resonance.

Storage

Long time storage after using the valve for water will require complete removal of moisture in order to prevent corrosion and deterioration of rubber parts.

Long Period Energization or Deenergization

The valve switching period depends on the type and quality of the fluid. When pure water is taken as a standard, the valve should be switched at least once every 10 days. If the cycle is greater than 10 days, a system check mechanism should be installed. The valve is not intended to be used as an emergency Circuit breaker. Specify operational conditions for use under conditions similar to that.

Fluid Temperature

Refer to the temperature range for each model. The temperature range changes according to the sealing material, coil insulation, power, supply, etc. Contact our representative for use other than standard use.

Applicable Fluid

- ① Fluid Classification
When selecting a valve for your application, ensure the compatibility of the fluid and valve materials. Generally, the recommended viscosity of fluid is 50cSt max.
For further details, contact our representative.
<Reference> Standard materials
Body:Brass or BC6 Seal:NBR, Coil:Insulation Type B.
These are for water, air, and oil use. For materials other than standard, refer to the "Option list" and "Applicable fluid check list." The specifications may be slightly different.
- ② Fluid Quality
Fluid mixed with foreign material can promote wear of the valve seat and iron core. Adhesion of foreign particles to the iron core and sliding section can cause degraded function of the valve or sealing trouble. To prevent this, place a filter(strainer)immediately in front of the solenoid valve. In general, a mesh of 80~100 is recommended.
- ③ Lubricant
Our solenoid valves do not need lubrication. However, lubricated air will increase their life.
- ④ In using inflammable oil and gas, prevention of leakage both inside and outside of the valve should be exercised.
- ⑤ In case oil and other impurities are not allowed in the fluid, use nonlube treated parts.
- ⑥ Under conditions near the limit of valve operation, the option and fluid may not be applicable as they are since only general applications are shown, check actual conditions on your own for appropriate selection.

DW

DV100

DV1000 ·
3000 · 4000

DS300

DS3000

DS5000

DS2000

DX2R

DP300 ·
3000 · 5000

DS6000

DX2

DM

DH

DT220

DC