



High-low System Block

50 to 100 ℓ /min
25MPa

Features

Simple high-low 2-speed control can be attained by stacking this block on top of a high-low base block and manifold, which configures a speed control circuit.

Specifications

Model No.	Nominal Diameter (Size)	Maximum Working Pressure MPa(kgf/cm ²)	Maximum Flow Rate ℓ /min	Weight kg
OB-G01-W-20	1/8	25{255}	50	1.5
OB-G01-W-H-20				2.5
OB-G03-W-J30	3/8	25{255}	100	4.5
OB-G03-W-H-J30				7.1

● Handling

① If a base block is required, use MOB-01Y-W*-10 for the 01 size and MOB-03X-B*-J30 for the 03 size, because their valve pitches match. MOB-01X-B*-10 has a different valve pitch, and so cannot be used.

② When installing this block, make sure the nameplate is oriented so it can be read correctly from the A port side.

③ Both of the cylinder ports on this block's manifold side (bottom) are open. Because of this, close one of the base block cylinder ports (A1,

B1 or A2, B2 on the next page), or modify the manifold so it has a single cylinder port only.

④ Note that installation bolts are not included. See pages D-90 through D-95 if these items are required.

Understanding Model Numbers

OB - G 01 - W - (H) - 20

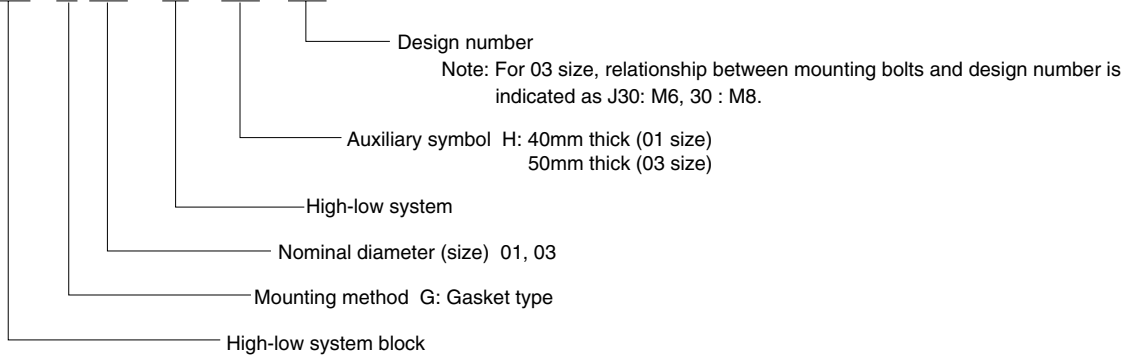

Installation Dimension Drawings

OB-G01-W-20

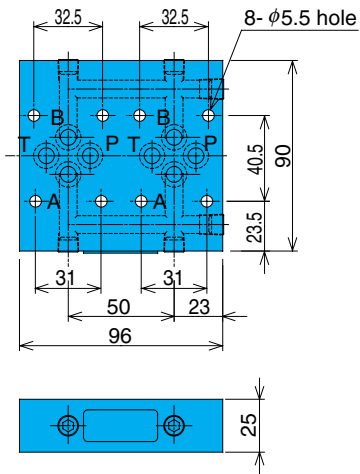

OB-G01-W-H-20

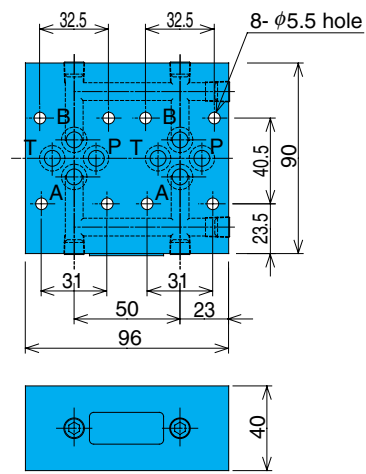

OB-G03-W-J30

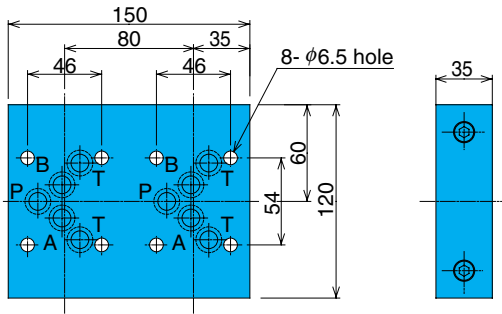

OB-G03-W-H-J30

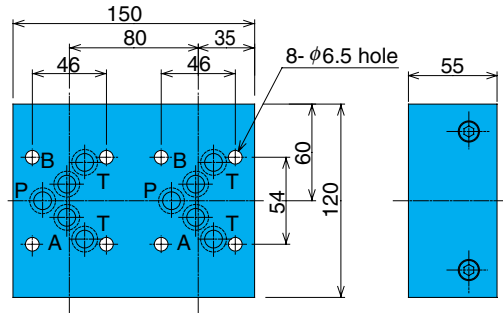

Example of Typical Circuit

